



VT Hackney

A company of VT Systems



Model PL0973 Medium Rescue



Sourcewell 
Formerly NJPA

Awarded Contract

Contract # 022818-VTH

PL-0973

Hackney Emergency Vehicles

NJPA - HACKNEY PL0973

Sales Rep:

Terms:

Drawing #:

Est. Delivery Date: / /

Customer PO #:

Penalty:

Customer #:

QPF #:

Exp. Date: 02/11/2018

Quote No: 10145-0002

BODY: XPL200 NJPA PL0973 RESCUE

08/17/2018

Page 1

PART NO	DESCRIPTION	QTY
== NJPA PL0973 RESCUE - ==		1
== QW RELEASE - Effective 01-02-18 ==		1
CAB and CHASSIS		1
10-02-0300	FREIGHTLINER M2-106 2-DOOR - CUMMINS ISL-330	1
10-19-0000	FLUID LEVEL DATA PLATE - VISIONMUX	1
10-19-1010	WELDON VEHICLE DATA RECORDER (VDR) - VISIONMUX - NFPA 1901-2009	1
10-19-1025	"MUST BE SEATED AND BELTED" - WARNING PLATE	1
10-19-1045	WARNING PLATE - VEHICLE SPECIFICATION DATA	1
10-19-1075	"DO NOT WEAR HELMET WHILE SEATED" - WARNING PLATE	1
10-99-1600	EXHAUST, VERTICAL STACK - OEM INSTALLED	1
11-16-0220	BATTERY CONDITIONER - PROGRESSIVE DYNAMICS	1
11-17-0015	SHOREPOWER- KUSSMAUL AUTO-EJECT - 15-AMP	1
11-31-5006	ENGINE COMP'T LIGHT - Centered on Firewall	1
11-33-0802	GROUND LIGHTS - TECNIQ LED - FRONT CAB DOOR (PR)	1
12-00-1010	MUD FLAPS - RE-INSTALL CHASSIS OEM	1
12-10-1000	CAB STEP - RIGHT SIDE - 2-DR	1
12-11-1000	FUEL TANK COVER/STEP - FREIGHTLINER - 2-DR	1
12-11-1900	ULTRA-LOW SULFUR DIESEL FUEL ONLY LABEL	1
12-11-1950	DEF FLUID LABEL	1
12-57-0021	TIRE PRESSURE MONITORING - REALWHEELS AIRSECURE - 6-WHL	1
16-10-1510	TOW EYE PLATES - REAR - BLACK (PR)	1
BODY and FRAME OPTIONS		1
20-00-3500	FRAME RAIL MODIFICATION - PL BODY W/ REAR DROP FRAME	1
20-02-0000	BODY CONSTRUCTION - HEAVY RESCUE	1

PART NO	DESCRIPTION	QTY
20-11-0906	BODY - PL0973 - 9 COMP'T - 73"/48"	1
20-49-9000	OVERALL HEIGHT PLATE	1
20-61-0200	ROLLERS, STAINLESS STEEL ROLL-UP DOOR - ILOS - (Ea. Comp't Door)	9
20-71-0020	WHEELHOUSING SKIRT PANEL - PAINTED	1
20-71-0320	FENDERETTES, STAINLESS STEEL (PR)	1
EXTERIOR BODY OPTIONS		1
22-21-0010	STONE GUARDS, FRT & REAR - D/P - (4) - up to 73"H	1
22-25-2000	BUMPER, REAR STEP BRIGHT TREAD PLATE	1
22-25-5500	SIGN - "DANGER - DO NOT RIDE ON REAR STEP"	1
22-33-1000	STEP, REAR WHEEL ALUMINUM STEP (PR)	1
22-40-0100	HOLDER FOR WHEEL CHOCK - ZICO SQCH-44 (EA)	2
22-40-2100	WHEEL CHOCK BRACKET - VERTICAL FOR ZICO AC-44 (EA)	2
22-50-3010	LICENSE PLATE INSERTS & LIGHT	1
22-51-1000	MUD FLAPS, REAR (PR) BLACK RUBBER	1
INTERIOR BODY OPTIONS		1
23-11-0550	RECESSED ADJUSTABLE SHELF TRACK (EA)	9
23-11-2101	SHELF - EXTENDED FLOOR - PERMANENT (EA)	4
EXTERIOR BODY OPTIONS		1
PAINT and GRAPHICS		1
40-00-0012	PAINT BODY - HEAVY RESCUE - ONE COLOR	1
41-00-0000	DO NOT RE-PAINT CAB	1
42-12-0000	TOUCH UP PAINT - ONE QUART	1
42-90-0500	COMPARTMENT WALLS/FLOORS COATING - MULTISPEC (ea. comp't)	9
42-99-0000	UNDERCOATING CAB, FRAME & BODY	1
43-20-2000	STRIPE, REFLECTIVE 4" PRICE PER FOOT REQS DWG	60
43-20-8025	CHEVRON STRIPE - REAR BODY W/NO REAR DOOR - HEAVY RESCUE	1
43-20-8120	REFLECTIVE STRIPING ACROSS FACE OF BUMPER	1
12VDC ELECTRICAL SYSTEM		1
50-00-0410	ELECTRICAL SYSTEM - V-MUX MULTIPLEX	1
50-05-0000	AMP DRAW REPORT - NFPA 1901, Section 9-15	1
50-06-1110	SAFETY INTERLOCK SYSTEM - MED/HD CHASSIS	1
50-10-0100	CAB CONSOLE - FLOOR MOUNT - INTERNATIONAL/FREIGHTLINER - VISIONMUX/V-MUX	1
50-20-0200	BRACKET- HAVIS-SHIELDS SIREN FOR WHELEN 295-Series	1
50-40-0110	CLEARANCE LIGHTS, LED & REFLECTORS W/CENTER REAR THIRD BRAKE	1
50-50-0200	TAIL LIGHT ASSY - LED STOP/TURN/BACKUP with CHROME BEZELS	1
50-50-6000	JAKE BRAKE LIGHT ACTIVATION	1
50-51-9000	AUXILIARY LED TURN SIGNALS - AMBER, CENTER BODY	1
51-10-1725	SCENE LIGHT - SIDE - WHELEN 90 LED OPTI-SCENE (EA)	4
51-10-2515	SCENE LIGHT - REAR - WHELEN 90 LED OPTI-SCENE (EA)	2
51-19-0110	GROUND LIGHTS - TECNIQ LED - UNDERBODY MOUNTED (EA)	5
51-19-0130	GROUND LIGHTS ACTIVATED BY TURN SIGNALS /REVERSE	1
51-50-1810	COMPARTMENT LIGHTS - LED STRIP - 24" RECESSED	7
51-50-1850	COMPARTMENT LIGHTS - LED STRIP - 42" RECESSED	2
51-55-1001	COMP'T OPEN WARNING & AUTO ACTIVATION - VISIONMUX	1
51-56-0100	COMP'T OPEN WARNING LIGHT - LED	1

PART NO	DESCRIPTION	QTY
SPOTLIGHTS & HANDHELD LIGHTS		1
NFPA 1901 WARNING LIGHTS		1
UPPER ZONE A - FRONT CAB WARNING LIGHTS		1
54-01-1556	WHELEN JUSTICE JE2NFPA - 56" LIGHT BAR - V-END Configuration	1
LOWER ZONE A - FRONT CAB WARNING LIGHTS		1
54-10-07RC	WHELEN C7LRC RED SURFACEMAX - CLEAR LENS W/C7FC CHROMED BEZEL (ea)	2
54-15-5000	HEADLIGHT WIG-WAG PATTERN - V-MUX	1
LOWER ZONE B/D - CAB INTERSECTION WARNING LIGHTS		1
54-20-05RC	WHELEN 50R02ZCR RED SUPER-LED - CLEAR LENS W/5TSMAC CHROME BEZEL (ea)	2
LOWER ZONE B/D - SIDE BODY WARNING LIGHTS		1
54-21-06RC	WHELEN C6LRC RED SURFACEMAX - CLEAR LENS W/C6FC CHROMED BEZEL (ea)	4
LOWER ZONE C - REAR BODY WARNING LIGHTS		1
54-25-06RC	WHELEN C6LRC RED SURFACEMAX - CLEAR LENS W/C6FC CHROMED BEZEL (ea)	2
UPPER ZONE B/D - SIDE BODY WARNING LIGHTS		1
54-30-09RC	WHELEN C9LRC RED SURFACEMAX - CLEAR LENS W/C9FC CHROMED BEZEL (ea)	4
UPPER ZONE C - REAR BODY WARNING LIGHTS		1
54-31-09RC	WHELEN C9LRC RED SURFACEMAX - CLEAR LENS W/C9FC CHROMED BEZEL (ea)	2
AUDIBLE WARNING DEVICES		1
55-22-1000	SIREN - WHELEN ELECTRONIC - 295SLSA1	1
55-30-1000	HORN/SIREN SWITCH	1
55-41-4020	SPEAKER, SIREN - FREIGHTLINER M2 - THROUGH-THE-BUMPER (EA)	1
58-50-1000	12VDC POWER STRIP - (6) TERMINALS - CAB	1
58-80-1000	BACK-UP ALARM - FEDERAL 210333	1
58-82-0000	REARVIEW COLOR CAMERA W/NIGHTVISION & MONITOR - Visionmux	1
59-59-0000	ANTENNA COAXIAL W/CONNECTOR - MOTOROLA 17'	1
120/240VAC ELECTRICAL SYSTEM		1
AIR SYSTEMS		1
89-99-9600	DOT SAFETY KIT	1
ADMINISTRATIVE - FIXED		1
98-01-1000	MANUAL, HACKNEY OWNERS W/SCHEMATICS	1
98-10-1500	PRE-DELIVERY CLEAN-UP - CAB & BODY	1

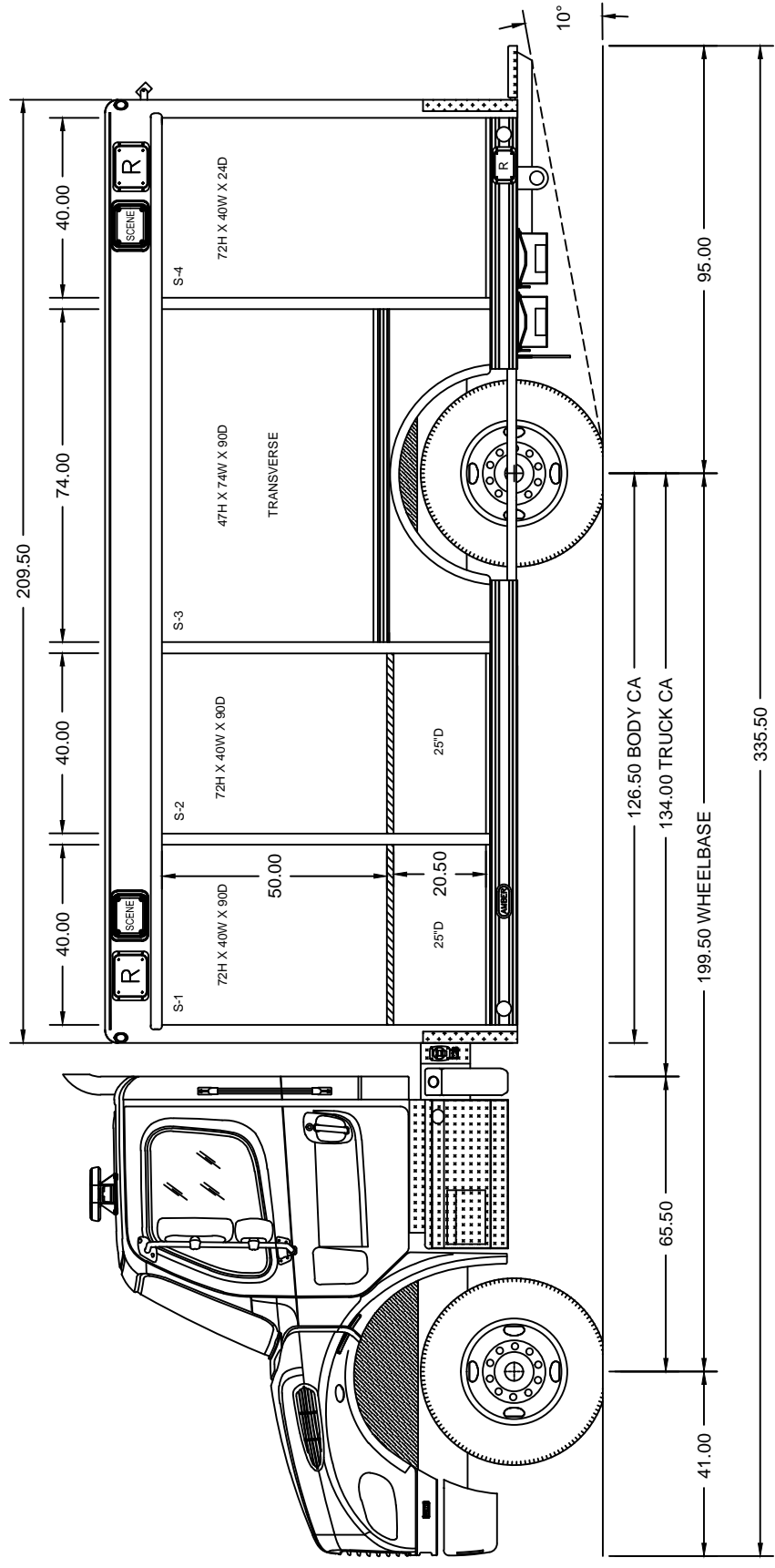

STREETSIDE EXTERIOR

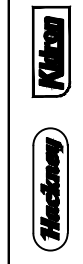

THIS PRINT AND ALL RIGHTS TO THE DESIGN AND DETAIL...
 CONTENTS ARE CONFIDENTIAL AND MUST NOT BE COPIED...
 COPYRIGHT 2015 VT HACKNEY A COMPANY OF VT SYSTEMS

DATE: 02/01/18		CUSTOMER: NJPA	
DRAWN BY: EES		PROJECT: PL-0973	
SHEET: 2 OF 3		SCALE: 25	
MODEL: PL-0973		DRAWING NO: CONTRACT #	
WASHINGTON, NC 27889-0880		REV: -	

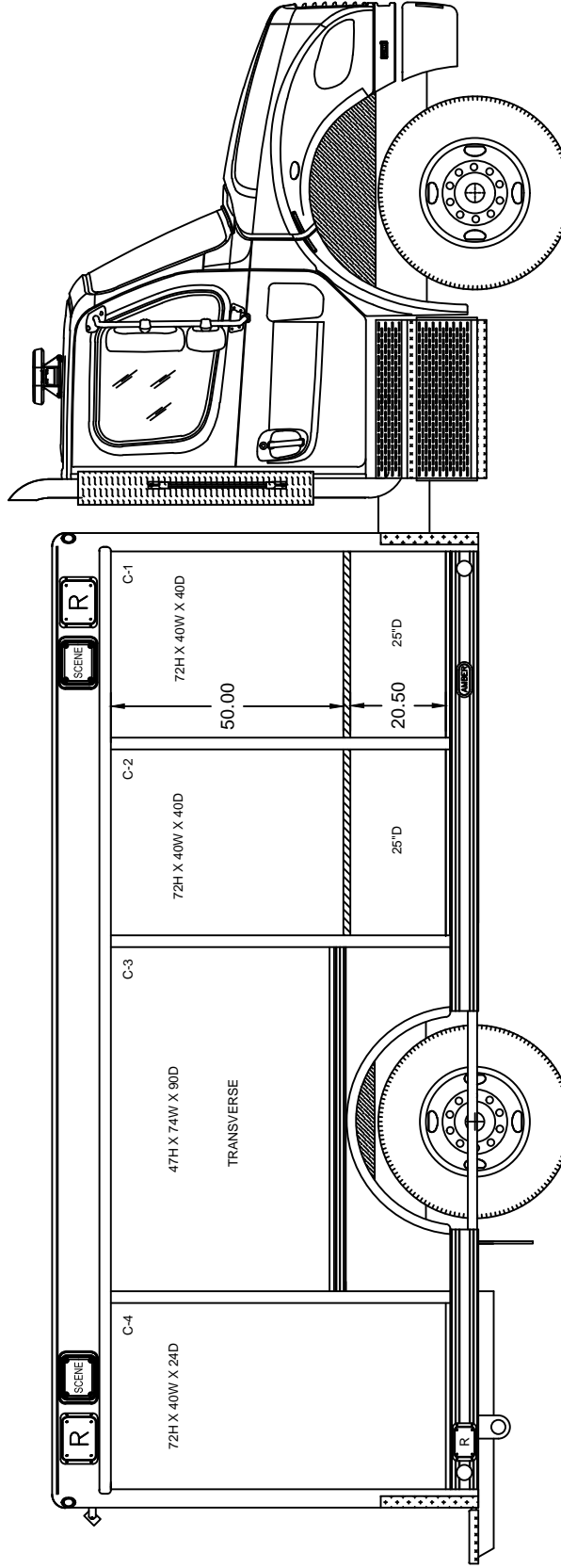

CURBSIDE EXTERIOR

THIS PRINT AND ALL RIGHTS TO THE DESIGN AND DETAIL ARE RESERVED BY VT HACKNEY INC. ANY REUSE OR REPRODUCTION OF THIS CONTENT IS STRICTLY PROHIBITED. ALL RIGHTS RESERVED. CONTENTS ARE CONFIDENTIAL AND MUST NOT BE COPIED, REPRODUCED, OR TRANSMITTED IN ANY FORM OR BY ANY MEANS, ELECTRONIC OR MECHANICAL, INCLUDING PHOTOCOPYING, RECORDING, OR BY ANY INFORMATION STORAGE AND RETRIEVAL SYSTEM. COPYRIGHT 2015 VT HACKNEY A COMPANY OF VT SYSTEMS

VT Hackney
A company of VT Systems
WASHINGTON, NC 27889-0880

DATE: 02/01/18
SHEET: 1 OF 3
MODEL: PL-0973
SCALE: 25
DRAWING NO: NJPA CONTRACT #

CUSTOMER: NJPA
CUSTOMER DESIGN FOR: NJPA
REV: -

© 2015 VT HACKNEY INC
NOTE: ESTIMATED DIMENSIONS
MEASUREMENTS DEPEND ON CHASSIS,
TIRES, SPRINGS, AND LOADING.

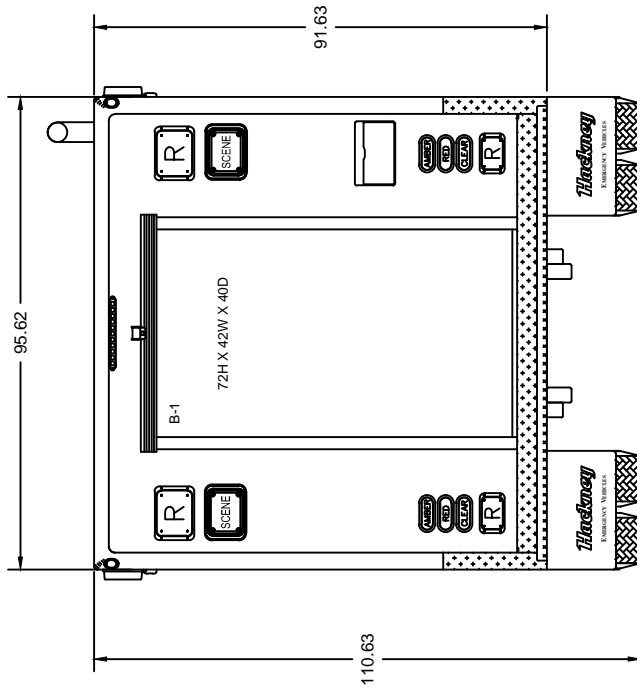

REAR VIEW

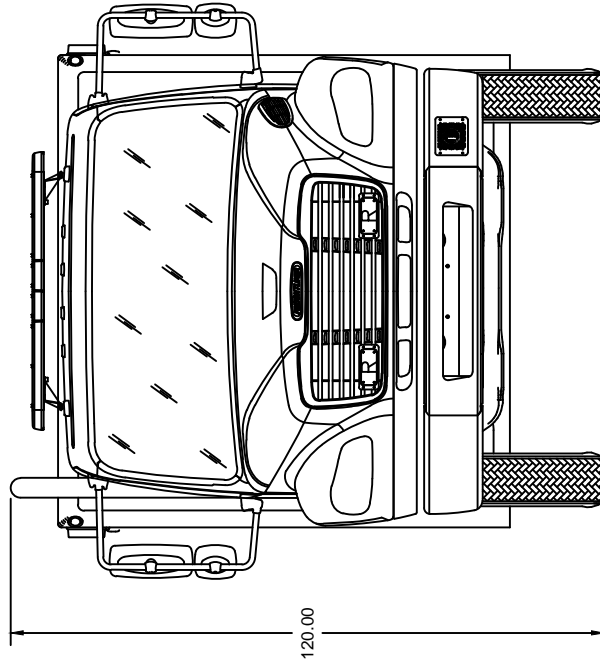

FRONT VIEW

THIS PRINT AND ALL RIGHTS TO THE DESIGN AND DETAIL, AND THE CONTENTS HEREIN, ARE THE PROPERTY OF VT HACKNEY INC. AND WILL REMAIN THE PROPERTY OF VT HACKNEY INC. IF THE CONTENTS ARE CONFIDENTIAL AND MUST NOT BE COPIED, REPRODUCED, OR TRANSMITTED IN ANY FORM OR BY ANY MEANS, WITHOUT THE WRITTEN PERMISSION OF VT HACKNEY INC. COPYRIGHT 2015 VT HACKNEY A COMPANY OF VT SYSTEMS

VT Hackney
A company of VT Systems
WASHINGTON, NC 27889-0880



DATE: 02/01/18
CUSTOMER: NJPA

SHEET: 3 OF 3

CONTRACT #

DRAWING NO.

SCALE: 25

MODEL: PL-0973

© 2015 VT HACKNEY INC
NOTE: ESTIMATED DIMENSIONS
MEASUREMENTS DEPEND ON CHASSIS,
TIRES, SPRINGS, AND LOADING.

REV: -