



# VT Hackney

A company of VT Systems



## Model PL1182 Heavy Rescue

**Hackney**

Sourcewell   
Formerly NJPA

Awarded Contract

#022818-VTH

PL-1182

Hackney Emergency Vehicles

NJPA - HACKNEY PL1182 - 11 COMP'T - 82"/57"

Sales Rep:

Terms:

Drawing #:

Est. Delivery Date: / /

Customer PO #:

Penalty:

Customer #:

QPF #:

Exp. Date: 02/11/2018

Quote No: 10142-0002

BODY: XPL500 NJPA PL1182 - RESCUE

08/17/2018

Page 1

PART NO	DESCRIPTION	QTY
== NJPA PL1182 - RESCUE - ==		1
== QW RELEASE - Effective 01-02-18 ==		1
CAB and CHASSIS		1
10-02-0300	FREIGHTLINER M2-106 2-DOOR - CUMMINS ISL-330	1
10-19-0000	FLUID LEVEL DATA PLATE - VISIONMUX	1
10-19-1010	WELDON VEHICLE DATA RECORDER (VDR) - VISIONMUX - NFPA 1901-2009	1
10-19-1025	"MUST BE SEATED AND BELTED" - WARNING PLATE	1
10-19-1045	WARNING PLATE - VEHICLE SPECIFICATION DATA	1
10-19-1075	"DO NOT WEAR HELMET WHILE SEATED" - WARNING PLATE	1
10-41-0000	HOLDER - UNIVERSAL HELMET - ZIAMATIC (EA)	2
10-99-1600	EXHAUST, VERTICAL STACK - OEM INSTALLED	1
11-16-0220	BATTERY CONDITIONER - PROGRESSIVE DYNAMICS	1
11-17-0020	SHOREPOWER INLET, 20 AMP W/COVER & FEMALE PLU	1
11-31-5005	ENGINE COMP'T LIGHT - Centered Under Hood	1
11-33-0802	GROUND LIGHTS - TECNIQ LED - FRONT CAB DOOR (PR)	1
12-00-1010	MUD FLAPS - RE-INSTALL CHASSIS OEM	1
12-10-1000	CAB STEP - RIGHT SIDE - 2-DR	1
12-11-1000	FUEL TANK COVER/STEP - FREIGHTLINER - 2-DR	1
12-11-1900	ULTRA-LOW SULFUR DIESEL FUEL ONLY LABEL	1
12-11-1950	DEF FLUID LABEL	1
12-57-0021	TIRE PRESSURE MONITORING - REALWHEELS AIRSECURE - 6-WHL	1
16-10-1510	TOW EYE PLATES - REAR - BLACK (PR)	1
BODY and FRAME OPTIONS		1
20-00-3500	FRAME RAIL MODIFICATION - PL BODY W/ REAR DROP FRAME	1

PART NO	DESCRIPTION	QTY
20-02-0000	BODY CONSTRUCTION - HEAVY RESCUE	1
20-11-4005	BODY - PL1182 - 11 COMP'T - 82"/57"	1
20-49-9000	OVERALL HEIGHT PLATE	1
20-61-0200	ROLLERS, STAINLESS STEEL ROLL-UP DOOR - ILOS - (Ea. Comp't Door)	11
20-71-0020	WHEELHOUSING SKIRT PANEL - PAINTED	1
20-71-0120	FRONT BODY PANEL - PAINTED	1
20-71-0320	FENDERETTES, STAINLESS STEEL (PR)	1
20-72-2000	FUEL FILLER - W/HINGED ACCESS DOOR - CPI	1
20-72-3000	ULTRA-LOW SULFUR DIESEL FUEL ONLY LABEL	1
<b>EXTERIOR BODY OPTIONS</b>		<b>1</b>
22-21-0010	STONE GUARDS, FRT & REAR - D/P - (4) - up to 73"H	1
22-25-2000	BUMPER, REAR STEP BRIGHT TREAD PLATE	1
22-25-5500	SIGN - "DANGER - DO NOT RIDE ON REAR STEP"	1
22-33-1000	STEP, REAR WHEEL ALUMINUM STEP (PR)	1
22-40-0090	WHEEL CHOCK - ZICO COLLAPSIBLE TYPE (EA)	2
22-40-0100	HOLDER FOR WHEEL CHOCK - ZICO SQCH-44 (EA)	2
22-50-3005	LICENSE FRAME W/LIGHT-SURFACE MNT-CPI C30004	1
22-51-1000	MUD FLAPS, REAR (PR) BLACK RUBBER	1
<b>INTERIOR BODY OPTIONS</b>		<b>1</b>
23-11-0550	RECESSED ADJUSTABLE SHELF TRACK (EA)	11
23-11-2101	SHELF - EXTENDED FLOOR - PERMANENT (EA)	6
<b>EXTERIOR BODY OPTIONS</b>		<b>1</b>
<b>PAINT and GRAPHICS</b>		<b>1</b>
40-00-0011	PAINT BODY - MEDIUM RESCUE - ONE COLOR	1
41-00-0000	DO NOT RE-PAINT CAB	1
42-90-0500	COMPARTMENT WALLS/FLOORS COATING - MULTISPEC (ea. comp't)	11
42-99-0000	UNDERCOATING CAB, FRAME & BODY	1
43-20-2000	STRIPE, REFLECTIVE 4" PRICE PER FOOT REQS DWG	80
43-20-8025	CHEVRON STRIPE - REAR BODY W/NO REAR DOOR - HEAVY RESCUE	1
43-20-8120	REFLECTIVE STRIPING ACROSS FACE OF BUMPER	1
<b>12VDC ELECTRICAL SYSTEM</b>		<b>1</b>
50-00-0410	ELECTRICAL SYSTEM - V-MUX MULTIPLEX	1
50-05-0000	AMP DRAW REPORT - NFPA 1901, Section 9-15	1
50-06-1110	SAFETY INTERLOCK SYSTEM - MED/HD CHASSIS	1
50-40-0110	CLEARANCE LIGHTS, LED & REFLECTORS W/CENTER REAR THIRD BRAKE	1
50-51-9000	AUXILIARY LED TURN SIGNALS - AMBER, CENTER BODY	1
51-19-0110	GROUND LIGHTS - TECNIQ LED - UNDERBODY MOUNTED (EA)	7
51-19-0130	GROUND LIGHTS ACTIVATED BY TURN SIGNALS /REVERSE	1
51-50-1810	COMPARTMENT LIGHTS - LED STRIP - 24" RECESSED	8
51-50-1943	COMPARTMENT LIGHTS - LED STRIP - 43" SURFACE	3
51-55-1001	COMP'T OPEN WARNING & AUTO ACTIVATION - VISIONMUX	1
51-55-2000	COMP'T OPEN WARNING BUZZER	1
51-56-0100	COMP'T OPEN WARNING LIGHT - LED	1
<b>NFPA 1901 WARNING LIGHTS</b>		<b>1</b>

PART NO	DESCRIPTION	QTY
<b>UPPER ZONE A - FRONT CAB WARNING LIGHTS</b>		<b>1</b>
54-01-1556	WHELEN JUSTICE JE2NFPA - 56" LIGHT BAR - V-END Configuration	1
54-01-9902	BRACKET, LIGHTBAR CAB ROOF MOUNTING -Whelen	1
<b>LOWER ZONE A - FRONT CAB WARNING LIGHTS</b>		<b>1</b>
54-10-07RC	WHELEN C7LRC RED SURFACEMAX - CLEAR LENS W/C7FC CHROMED BEZEL (ea)	2
54-15-5000	HEADLIGHT WIG-WAG PATTERN - V-MUX	1
<b>LOWER ZONE B/D - CAB INTERSECTION WARNING LIGHTS</b>		<b>1</b>
54-20-05RC	WHELEN 50R02ZCR RED SUPER-LED - CLEAR LENS W/5TSMAC CHROME BEZEL (ea)	2
<b>LOWER ZONE B/D - SIDE BODY WARNING LIGHTS</b>		<b>1</b>
54-21-06RC	WHELEN C6LRC RED SURFACEMAX - CLEAR LENS W/C6FC CHROMED BEZEL (ea)	4
<b>LOWER ZONE C - REAR BODY WARNING LIGHTS</b>		<b>1</b>
54-25-06RC	WHELEN C6LRC RED SURFACEMAX - CLEAR LENS W/C6FC CHROMED BEZEL (ea)	2
<b>UPPER ZONE B/D - SIDE BODY WARNING LIGHTS</b>		<b>1</b>
54-30-09RC	WHELEN C9LRC RED SURFACEMAX - CLEAR LENS W/C9FC CHROMED BEZEL (ea)	4
<b>UPPER ZONE C - REAR BODY WARNING LIGHTS</b>		<b>1</b>
54-31-09RC	WHELEN C9LRC RED SURFACEMAX - CLEAR LENS W/C9FC CHROMED BEZEL (ea)	2
<b>AUDIBLE WARNING DEVICES</b>		<b>1</b>
55-22-1000	SIREN - WHELEN ELECTRONIC - 295SLSA1	1
55-30-1000	HORN/SIREN SWITCH	1
55-41-4020	SPEAKER, SIREN - FREIGHTLINER M2 - THROUGH-THE-BUMPER (EA)	1
58-50-1000	12VDC POWER STRIP - (6) TERMINALS - CAB	1
58-80-1000	BACK-UP ALARM - FEDERAL 210333	1
58-82-0000	REARVIEW COLOR CAMERA W/NIGHTVISION & MONITOR - Visionmux	1
59-59-0000	ANTENNA COAXIAL W/CONNECTOR - MOTOROLA 17'	1
<b>120/240VAC ELECTRICAL SYSTEM</b>		<b>1</b>
<b>AIR SYSTEMS</b>		<b>1</b>
89-99-9600	DOT SAFETY KIT	1
<b>ADMINISTRATIVE - FIXED</b>		<b>1</b>
98-01-1000	MANUAL, HACKNEY OWNERS W/SCHEMATICS	1
98-10-1500	PRE-DELIVERY CLEAN-UP - CAB & BODY	1
98-11-1000	FUEL TANK FULL AT FACTORY DELIVERY (up to 50-gallon tank)	1
98-70-1010	CHASSIS HANDLING FEE - COMMERCIAL	1



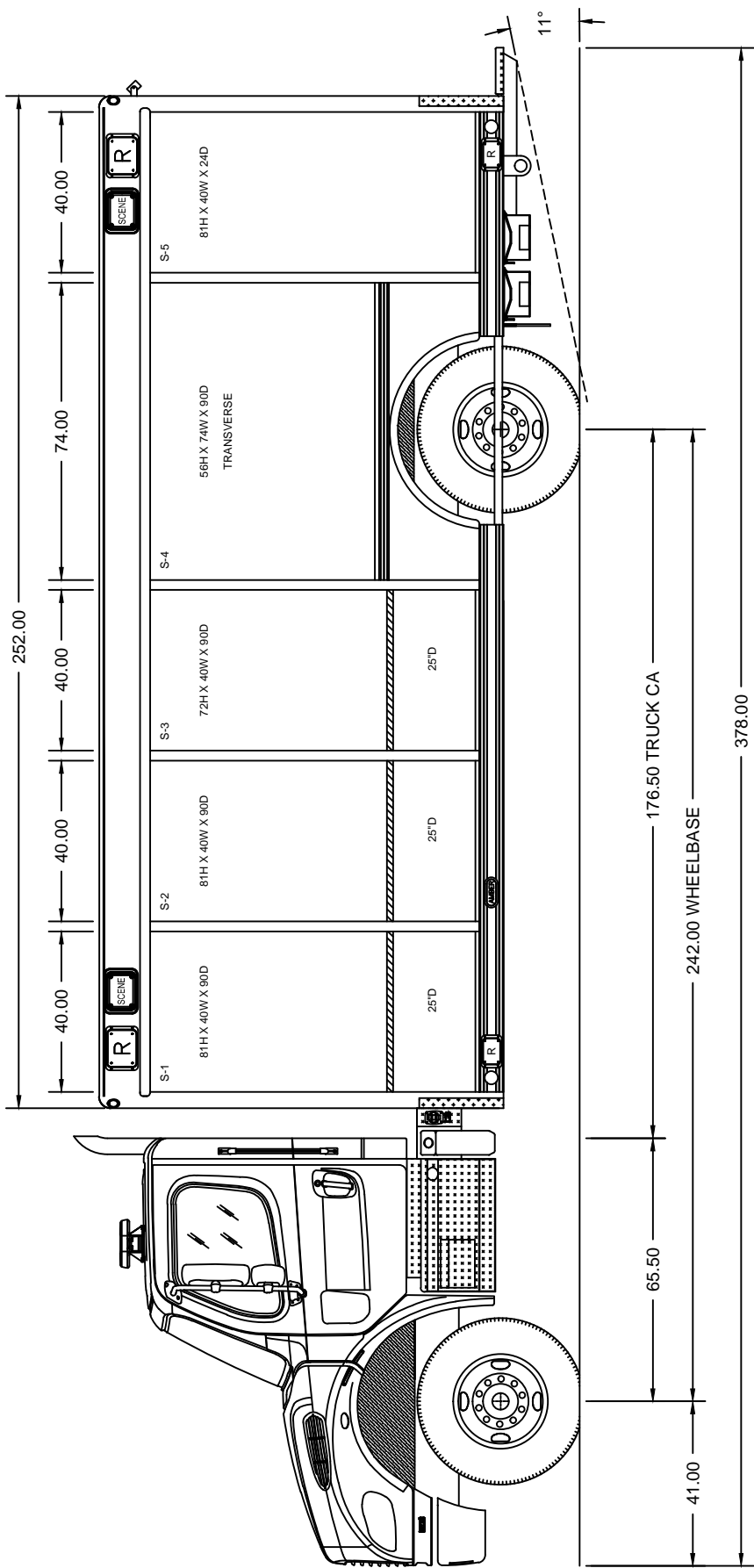

STREETSIDE EXTERIOR

THIS PRINT AND ALL RIGHTS TO THE DESIGN AND DETAIL ARE RESERVED BY VT HACKNEY INC. ANY REPRODUCTION OF THIS CONTENT IS CONFIDENTIAL AND MUST NOT BE COPIED OR TRANSMITTED IN ANY FORM OR BY ANY MEANS WITHOUT THE WRITTEN PERMISSION OF VT HACKNEY INC. COPYRIGHT 2015 VT HACKNEY A COMPANY OF VT SYSTEMS

**VT Hackney**  
A company of VT Systems



WASHINGTON, NC 27889-0880

DATE: 02/01/18

SHEET: 2 OF 3

CUSTOMER: NJPA

CONTRACT #

MODEL: PL-1182

SCALE: 27

DRAWING NO.

REV: -

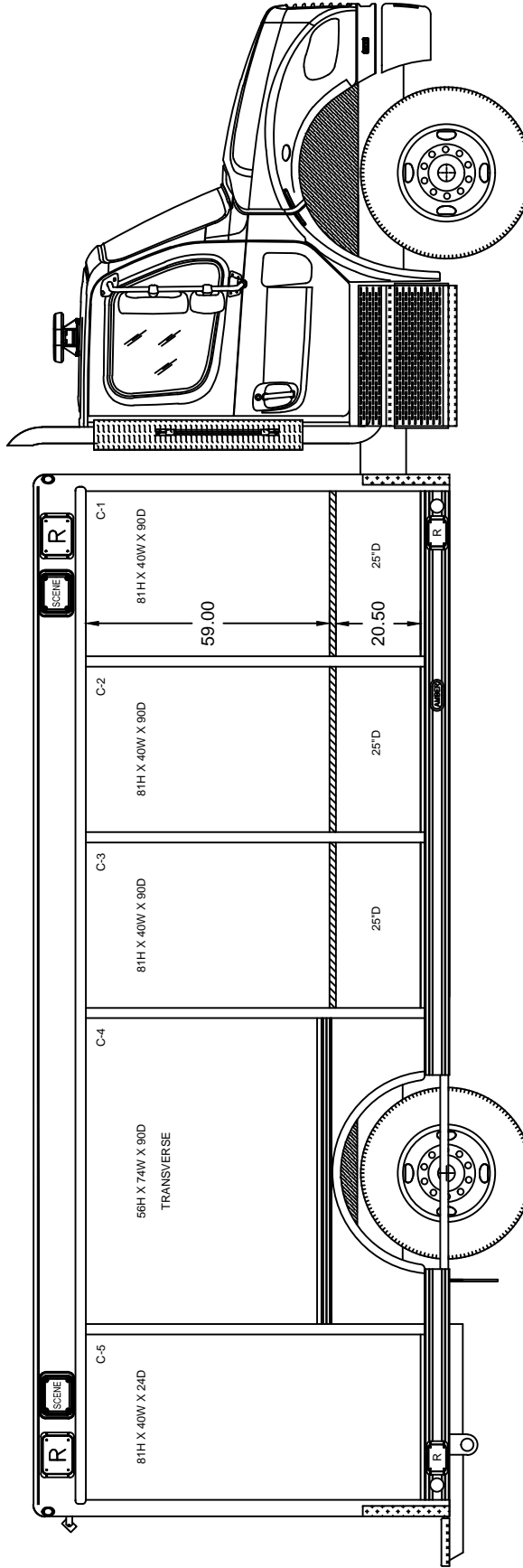

CURBSIDE EXTERIOR

THIS PRINT AND ALL RIGHTS TO THE DESIGN AND DETAIL  
 HEREIN ARE RESERVED BY VT HACKNEY INC. AND  
 TO THE EXTENT PERMITTED BY LAW, ALL RIGHTS  
 CONTENTS ARE CONFIDENTIAL AND MUST NOT BE COPIED,  
 REPRODUCED, OR TRANSMITTED IN ANY FORM OR  
 BY ANY MEANS, WITHOUT THE WRITTEN PERMISSION  
 COPYRIGHT 2015 VT HACKNEY A COMPANY OF VT SYSTEMS

© 2015 VT HACKNEY INC

NOTE: ESTIMATED DIMENSIONS  
 MEASUREMENTS DEPEND ON CHASSIS,  
 TIRES, SPRINGS, AND LOADING.



WASHINGTON, NC 27889-0880

DATE: 02/01/18

SHEET: 1 OF 3

MODEL: PL-1182

CUSTOMER: NJPA

CONTRACT #

SCALE: 27

DRAWING NO.

REV: -



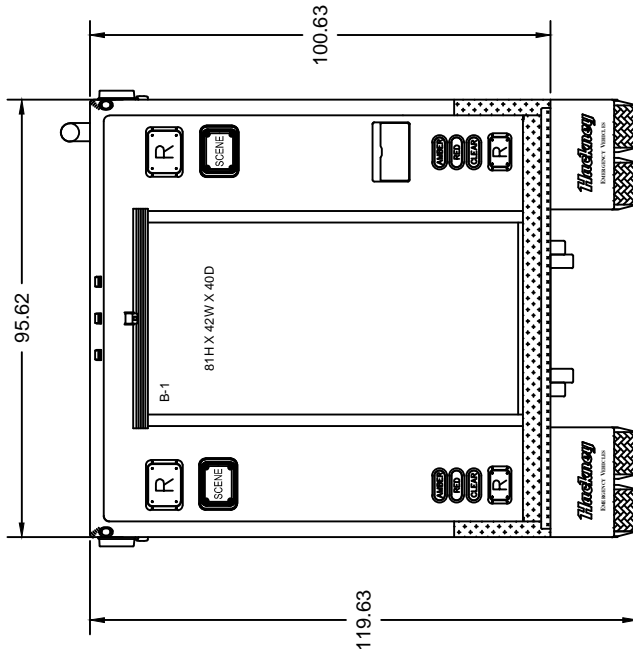

REAR VIEW

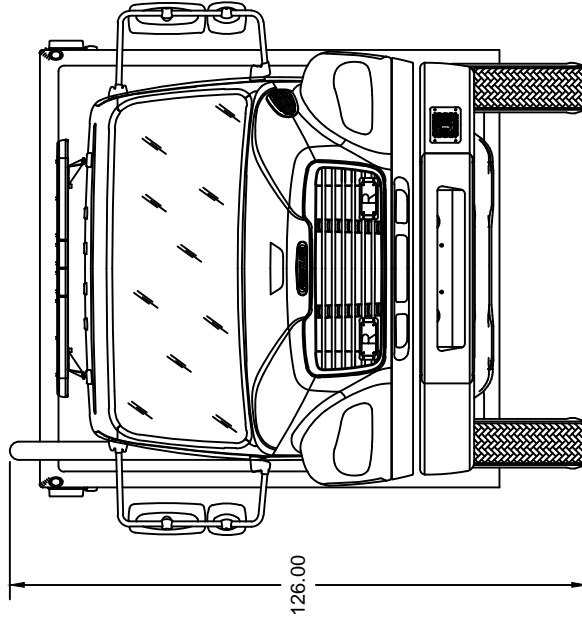

FRONT VIEW

THIS PRINT AND ALL RIGHTS TO THE DESIGN AND DETAIL, INCLUDING THE RIGHT OF REPRODUCTION, ARE RESERVED TO THE REQUIRER SUBJECT TO RETURN UPON DEMAND. ITS CONTENTS ARE CONFIDENTIAL AND MUST NOT BE COPIED OR REPRODUCED IN ANY MANNER WITHOUT THE WRITTEN PERMISSION OF VT HACKNEY A COMPANY OF VT SYSTEMS. COPYRIGHT 2015 VT HACKNEY A COMPANY OF VT SYSTEMS.

VT Hackney  
A company of VT Systems  
WASHINGTON, NC 27889-0880

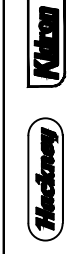

CUSTOM DESIGN FOR:

NJPA

DATE: 02/01/18



SHEET: 3 OF 3

CONTRACT #

SCALE

PL-1182

DRAWING NO.

27

REV: -

© 2015 VT HACKNEY INC

NOTE: ESTIMATED DIMENSIONS  
MEASUREMENTS DEPEND ON CHASSIS,  
TIRES, SPRINGS, AND LOADING.